

PixTM CONTROLLER

Trail Cameras and Portable Security Systems

DigitalEyeTM 7.2 Digital Trail Camera Instruction Manual



Copyright PixController, Inc., All rights reserved.

<http://www.pixcontroller.com>

sales@pixcontroller.com

(724) 733-0970

Getting Started

Thank you for your purchase of the PixController, Inc. DigitalEye™ 7.2 game scouting camera. This high-resolution digital game camera operates 24 hours a day, seven days a week, continually scouting game even when you're not in the woods.

This revolutionary trail camera features a Passive Infrared (PIR) triggering system. The PIR will trigger the camera based on "body heat and motion", and will detect game up to 80 feet from the camera.

The PixController, Inc. DigitalEye™ 7.2 incorporates the most advanced game detection electronics with the only auto-adjusting PIR on the market.

You can view your photos right in the woods on the digital camera's TFT color display. Never again will you have to spend money for 1-hour film developing!

Before using your camera charge up the Sony Li Ion battery and place it into the Sony 7.2 MegaPixel digital camera.

THE POWER SWITCH USES A 9VOLT BATTERY THAT COMES ALREADY INSTALLED. This battery will only need replaced every 3 months.

To stay on top of our product developments please visit:

<http://www.pixcontroller.com>

Packing List - DigitalEye™ 7.2 unit includes the following items:

- DigitalEye™ 7.2 Unit in rugged waterproof camo enclosure
- Sony 7.2 Mega Pixel Digital Camera (installed in DigitalEye™ 7.2 unit)
- Li Ion Battery & Charger
- Sony Digital Camera USB & Video Cables
- Digital Camera accessories
- Complete instruction manual
- Visual Media Explorer PC Photo Browser Software



DigitalEye™ 7.2 Overview

Listed below are the components of your DigitalEye™ 7.2 unit. These items will be referred to throughout this manual. Please become familiar with these items.



DigitalEye™ 7.2 Exterior



DigitalEye™ 7.2 Interior

DigitalEye™ 7.2 Control Board

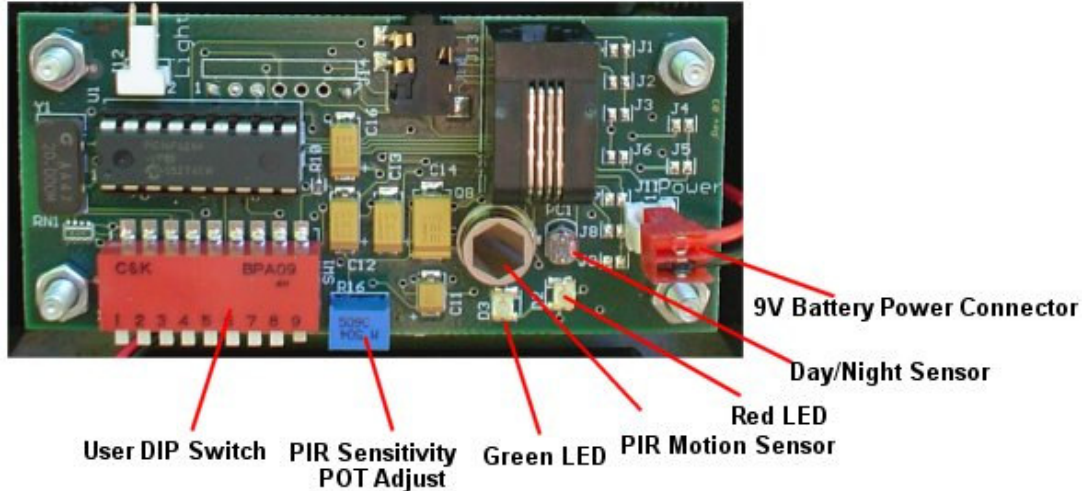

DigitalEye™ 7.2 Control Board Components

The DigitalEye™ 7.2™ Control Board electronics are the heart of the system. The DigitalEye™ 7.2 uses a Passive Infrared (PIR) sensor to detect any warm-blooded animal to trigger the camera. This sensor is triggered by body heat and motion.

The PIR sensor detects the difference between the air temperature and the animals' body heat temperature. In colder temperatures the detection distance is much greater. However, in air temperatures above 85 deg. F the detection distance can be cut by more than 20 feet. Under air temperatures around 65 deg. F your PIR detection range should be about 80 feet.

Setting the PIR sensitivity POT

The detecting distance adjustment allows you to easily set the PIR detecting distance (range). Passive infrared is more sensitive in winter than in summer, be sure to reduce the sensitivity in summer by adjusting the sensitivity knob away from the silver dot to avoid false triggering. Reducing the range for night photography will help the problems of your subject being out of the flash range.

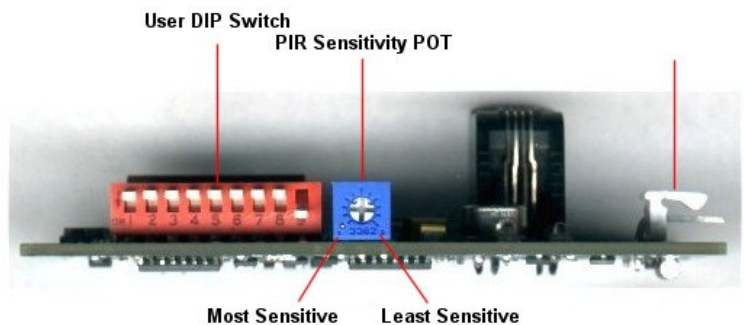

Bottom Edge

How to Setup the “User Switch Settings”

The User Switch will let you customize how the Camera Control Board will trigger the attached camera. Here you can adjust the time delay between pictures, operating only at day, night, or 24 hours, setting up a walk-test mode for testing PIR range/area, capturing Digital Stills or Movie Files, movie length, and turning the control board LED's on or off.



User DIP Switch

The user switch setting can be found here on the control board.

Note: *You must reboot the controller for changes to take place.*

Note1: When turning power on to your DigitalEye™ 7.2 both the red and green LED will light up. They will both stay on for 30 seconds. This time will allow the PIR circuit to warm up. After this time expires the green LED will turn off and the red LED will blink 5 times letting you know that the board is entering a 1 minute automatic walk-test phase. At this point you can move around the camera setup and check out the PIR area. Both the green and red LED's will light when motion is detected. After the 1 minute automatic walk-test phase expires the red LED will blink 5 times letting you know the camera system will now become active.

Default Setting



All switches “**UP**” except switch 9 which is “**DOWN**”.

10 Second Delay between pictures, 24 Hour Recording, 15 second MPEG movie length, Capture Still Picture, Control LED On, PIR LED On.

Red indicates the switch position for all graphics below. You may also refer to the switch detail located on the interior lid label of your DigitalEye™ 7.2.

Delays Between Pictures Setting

Switches 1, 2, and 3 control the delays between pictures.

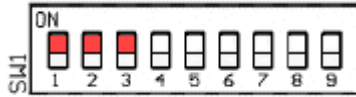

***Trail Mode™**

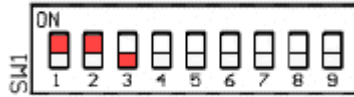

10 Seconds Delay

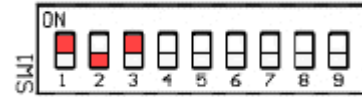

30 Seconds Delay

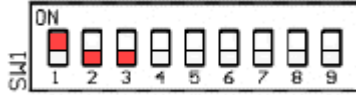

1 Minute Delay

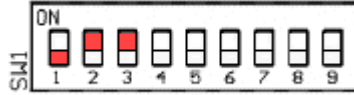

2 Minute Delay

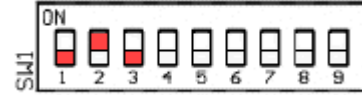

5 Minute Delay

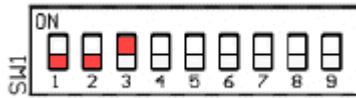

10 Minute Delay

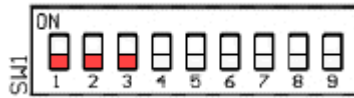

20 Minute Delay

How Trail Mode™ Works....



Trail Mode™ is an exclusive feature found only on PixController Trail Cameras. When setup in this mode your trail camera will keep the digital camera powered up after taking the first photo and will be take any subsequent photos in 1/10 of a second for a window time of 30 seconds. In the case a subsequent photo is taken the window of time is pushed out another 30 seconds. This will allow you to capture all of the animals coming down a trail and not just capture the first animal as you will in every other commercial trail camera on the market today.

Don't miss that shot of a trophy buck following a doe in heat!

Day/Night Operation Settings

Switches 4 and 5 control Daylight, Night Time, and 24 Hour recording or pictures.



24 Hour Operation



Night Only Operation



Day Only Operation

PIR Walk-Test Mode

On boot up of the DigitalEye™ 7.2 this setting will put the unit into a PIR Walk-Test mode. Here you can check out the PIR detection area without having the unit take photos. When booting the DigitalEye™ 7.2 into this mode the RED Control LED and Green PIR LED will stay on for about 30 seconds. This is when the PIR is warming up. After this period of time has expired you are free to walk and test the PIR area.

Note: To put the DigitalEye™ 7.2 back into “Photo Taking Mode” change the switch settings of switch 4 and 5 to one of the three options above under the Day/Night Operation Setting, and power the DigitalEye™ 7.2 unit Off and On from the external power switch.

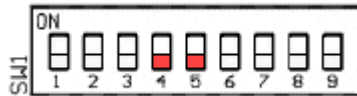

PIR Walk-Test Mode

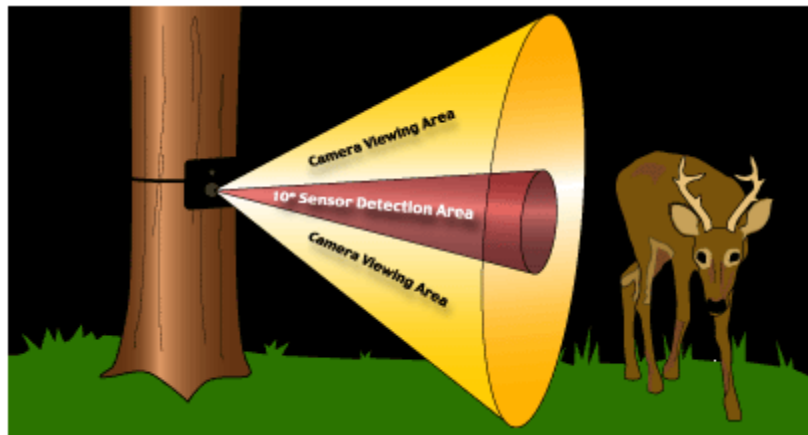

PIR Sensor Detection Area View

The PIR sensor detection area is an invisible cone shaped area. See the photo above. If you walk slowly through this zone the LED's will light. Using this simple technique you can determine the detection area.

Note: To put the DigitalEye™ 7.2 unit back into “Photo Taking Mode” change the switch settings of switch 4 and 5 to one of the three options above under the Day/Night Operation Setting, and power the DigitalEye™ 7.2 Unit Off and On from the unit power switch.

Picture Capture Setting

Switch 6 will allow the user to adjust how the camera shutter will function. The normal “Still Picture Setting” this will shutter the camera once to take a still photo. In the “Movie/Double Photo Mode” the shutter will be held open for 15-20 seconds for movie taking, or taking another still photo seconds after the first photo.

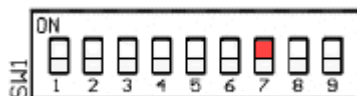

Still Picture Setting

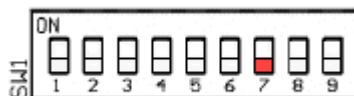

Movie/Double Photo Mode Setting

Movie Length

Switch 7 sets the length of the movie captured.

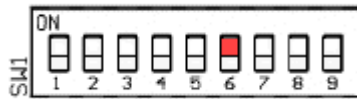

15 second movie

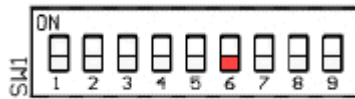

20 second movie

Control LED On/Off Setting

Switch 8 sets if the Control LED (Red LED) is to be used or not. Note, the control LED will always be on during the Power-Up Phase, or when in Walk-Test Mode.

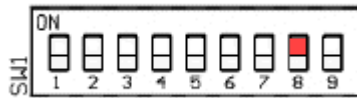

Control LED On

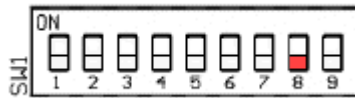

Control LED Of

PIR LED On/Off Setting

Switch 9 sets if the PIR LED (Green LED) is to be used or not.

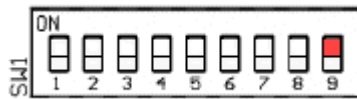

PIR LED Off

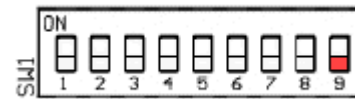

PIR LED On

Note:

When changing switch setting you must re-boot your DigitalEye™ 7.2 board. When re-booting you must wait approximately 30 seconds before turning power on again. Not doing so can result in the controller not working properly. Symptoms of this are a dim red LED or blinking green LED, or both.

Putting the DigitalEye™ 7.2 Out in the Woods...

Before using your camera charge up the Sony Li Ion battery and place it into the Sony 7.2 MegaPixel digital camera.

Before setting your DigitalEye™ 7.2 unit out in the woods be sure to read over the previous sections. Be sure to setup your User Switch Setting to the desired mode of operation.

The default mode is 10 seconds between photos (PIR delay), 24 hour photo taking mode, digital still photo taking mode, Red Control LED On, Green PIR LED On.

Find a secure tree or post to mount your DigitalEye™ 7.2 unit to in the woods. See the "Setup Tips" for more information on placing the unit in the woods.

Once the DigitalEye™ 7.2 unit is powered up the Red and Green LED's will turn on. You have a total of 2 minutes to hang the unit before the DigitalEye™ 7.2 will start taking photos. The Green PIR LED will shut off after about 20 seconds and will blink every time it sees motion. The Red Control LED will stay lit the entire 2-minute time period, then turn off. The Red Control LED will still light even if the User Switch Setting for this LED is turned off, however, if the User Switch Setting for the Green PIR LED is turned off the LED will not light.

Be sure you do not turn on the Sony digital camera. If you do the trail camera will not function. You must also wait the full 1.5 minute warm up period before your DigitalEye is ready to take photos.

Note: When hanging your DigitalEye™ 7.2 on a tree keep it about 2.5 feet to 3 feet above the ground. This will give you the optimal detection range.

Setting up the DigitalEye™ 7.2



1. Turn the unit power switch on.
2. **Make sure the Digital Camera is turned off**
3. **You must wait 1.5 minutes before your DigitalEye™ 7.2 can start taking photos**



4. Close the lid

Locking your DigitalEye™ 7.2 Unit

The DigitalEye™ 7.2 was designed such that it could be easily locked to any tree in the woods. To protect your investment we recommend using the Master Lock® Python™ Cable locking system. To lock your DigitalEye™ 7.2 unit, follow the 5-Step process below.

Step 1

Run the Master Lock® Python™ Cable system through the DigitalEye™ 7.2 Eye-Bolts as shown.



Step 2

Hold your DigitalEye™ 7.2 unit to the tree using your hip to hold it in place, and run the cable around the tree as shown.



Step 3

Next insert the cable into the locking head and pull tight. Use the weight of your body to press the cable flat against the DigitalEye™ 7.2 unit.



Step 4

Lock the Master Lock® Python™ Cable to the tree and remove the key.



Step 5

Your DigitalEye™ 7.2 camera system is now firmly locked to the tree and ready to take photos.



Checking your DigitalEye™ 7.2 Unit

When checking your DigitalEye™ 7.2 unit it's a good idea to carry a spare set of AA camera batteries and a spare memory card for the digital camera. Approach the DigitalEye™ 7.2 unit from the rear unless you want your photo taken. **Note: when you open the DigitalEye™ 7.2 lid a photo could be taken at this time before the unit power switch is turned off. The unit power switch was placed inside the DigitalEye™ 7.2 unit to prevent tampering with the unit.**

Step 1

Unlock the DigitalEye™ 7.2 unit (if locked) and open the lid. Next, power down the DigitalEye™ 7.2 unit by turning the main power switch to the "off" position.



Step 2

Unplug the camera cable. **Note: be sure the camera is turned off and the unit power switch is turned off before unplugging the camera cable.**

Note: Pull straight down, do not twist cable.



Note: Pull straight down, do not twist cable.

Step 3

You can now remove the digital camera from the DigitalEye™ 7.2 unit. You can review any photos taken by the DigitalEye™ 7.2 on the digital camera's TFT color display. Refer to your digital camera user manual for information on reviewing photos.



Problem Solving Tips and FAQ's

Problem/Question	Answer
Why is there sometimes nothing in my photo?	<p>Sometimes birds can fly past your camera setup and trigger the camera. A bird flying past can be too fast for the camera to catch.</p> <p>You may also have a "false photo". Sometimes on warmer days objects that heat up to warm blooded animal temperatures and move can fool the PIR into thinking an animal walked passed.</p> <p>See the "DigitalEye™ 7.2 Setup Tips".</p>
When I put my DigitalEye™ 7.2 unit into "Movie Mode" I still get still photos.	<p>Be sure to setup your digital camera into Movie taking mode. There is a switch at the top of the camera to set the mode as either photo or movie mode. Slide to switch to movie mode.</p>
How do I get my photos on to my computer?	<p>There are several ways you can transfer your digital photos to your computer. First you can remove the digital camera from the DigitalEye™ 7.2 unit and connect the supplied USB cable from the camera to your computer. Here you can copy any photos to your computer.</p> <p>You can also purchase a USB card reader. Here you can just swap media cards when checking your DigitalEye™ 7.2 unit and bring the media card home to transfer the photos.</p>
Is my media card reusable?	<p>Yes, your media card is reusable. You can think of it as "digital film". Simply copy your photos to your computer and delete them from your media card before using again.</p>
How many photos can I store on my media card?	<p>Depending on the size of media card you are using, you can store hundreds of photos at a time. See Sony manual for memory storage.</p>

The DigitalEye™ 7.2 Built-In Low Battery Indicator

When the batteries do not have sufficient charge, the DigitalEye™ 7.2 Green PIR LED will start blinking about once every ½ second. When this occurs it is time to replace the 9V Battery. Turn the “Unit Power Switch” to the off position and replace the batteries.

DigitalEye™ 7.2™ Setup Tips

1. Remove any brush or tall grass within about 10 feet of the DigitalEye™ 7.2 unit. This may interfere with the DigitalEye™ 7.2 PIR sensor and the ability to detect game. This will also help you see your subjects better in front of the camera. The flash will also wash out anything that is directly in front of the camera like a leaf or twig. If possible, take a second and stand back behind where you are going to mount the camera and look through the camera's viewfinder at the same level you are mounting it to see what the camera sees. This scene is what you are going to get on all your photos, so if something needs to be moved or trimmed, do it when you first set up the camera.
2. Never place your DigitalEye™ 7.2 pointing towards the sun rising or the sun setting (east or west). The sun can cause your camera system to take “false” photos. Try pointing the camera, north, northwest or northeast.
3. Attach your DigitalEye™ 7.2 to a firm tree or pole. Never attach it to a tree that can move in the wind. This can set off the camera system. If you don't have a lot of big thick trees to mount your cam to, you can improvise and use wooden stakes, barbed wire fence posts or rebar (reinforcing rod) to make a mount for your cam. Drive the stakes or rebar down a couple of feet, leaving about 3 or 4 feet above ground, then tie the rods or stakes together with some heavy solid electrical wire. If you are mounting your DigitalEye™ 7.2 to a tree, make sure you mount the camera to a tree that is at least 7 to 8 inches in diameter so that the wind will not sway the tree trunk and set off the camera.
4. The PIR sensor detects the difference between the air temperature and an animal's body heat temperature. In colder temperatures the detection distance is much greater. However, in air temperatures above 85 deg. F the detection distance can be cut by more than 20 feet. Air temperatures of 70 deg. F or below, your PIR detection range should be about 80 feet. During the summer months it is best to place your DigitalEye™ 7.2 in shaded areas.
5. Placing deer scent along the trail to get the deer to stop and investigate works well with trail camera systems. If you want better photos of the racks on bucks, put the scent up on a limb to get the buck to show off his rack better. If you're after varmints like bobcats or foxes, tie a feather onto a limb with some string so it will flutter in the breeze.
6. It is recommended that you use the Master Lock® Python™ Cable to lock your DigitalEye™ 7.2 unit every time you setup your system.

Visual Media Explorer™ Photo Browsing Software

Included on the DigitalEye™ 7.2 Installation CD is a copy of the powerful photo browsing software – Visual Media Explorer™. This software runs on any Win 95, 98, 2000, NT, and XP operating system.

Visual Media Explorer™ will let you view your photos in an easy to use browser. Here you can edit your photos, add time/date stamps, email photos to your family and friends, and much more!

Your DigitalEye™ 7.2 Installation CD includes an online manual and animated tutorials for Visual Media Explorer™.

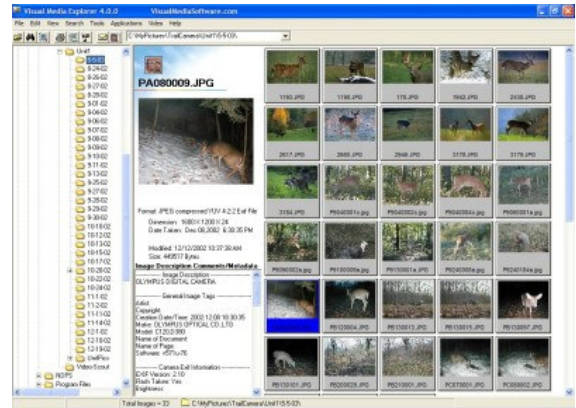

Visual Media Explorer™

Using a GPS with your DigitalEye™ 7.2

We recommend that you use a GPS unit to mark the location of your DigitalEye™ 7.2 unit. In the summer months especially you can easily lose your unit in the woods.

Secondly, if you do use a GPS unit along with your DigitalEye™ 7.2 you can embed the GPS position into the photos taken by the unit with your copy of Visual Media Explorer™. With the Visual Media Explorer™ upgrade you can stamp the GPS position on to your photos along with the time/date, and phase of the moon. You can even download aerial photos and topo maps from Microsoft's Terraserver. For Visual Media Explorer™ upgrades please visit:

<http://www.VisualMediaSoftware.com>



GPS Position Date Time
Moon Phase

Stamp your photos with GPS, Date/Time and Moon Phase information!



Save your DigitalEye™ 7.2 GPS Position.

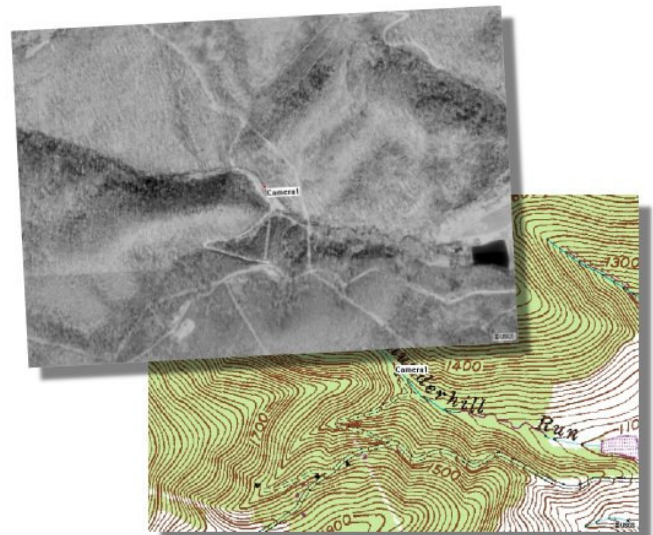

Get Aerial photos and Topo maps of your DigitalEye™ 7.2 GPS position.

Using Digital Media Card Readers (not included)

A nice addition to add to your DigitalEye™ 7.2 unit is a USB Digital Media card reader. Using a card reader will allow you to keep your DigitalEye™ 7.2 unit in the woods by just swapping media cards when checking the unit. Otherwise you must use the digital camera to transfer the photos to your computer via the included USB cable. Please refer to your digital camera manual for information about transferring your photos to your computer.



Digital Camera Settings

We suggest the following Sony 7.2 setting for maximum trail camera performance. Start off by putting the Sony 7.2 camera dial to the “P” setting for Program Setting

- Red Eye Reduction: Off
- AF Illuminator: Off
- Auto Review: Off
- Beep: Off
- Set your Date/Time
- Focus: 3m to 7m
- ISO 1000 (brightest night photos)
- Picture Quality: Fine
- AF in Monitor Mode

Unit Specifications

Size: 3-15/16 wide X 6-9/16” tall X 1-3/4” deep

Camera: 7.2 Mega Pixel Sony Digital Camera

Media Type: Sony Memory Stick PRO Duo

Flash Range: 30-40 Feet

PIR Detection Range: 40-80 Feet depending in air temperature

Photo delay: ~1.8 seconds

Photos per charge: ~300 (1/2 taken with flash)

DigitalEye™ 7.2 Batteries: 9V alkaline battery (lasting about 4-8 months) & Li Ion batteries in the Sony 7.2 camera lasting 300+ photos

Temperature range: 5°F to 110°F

Copyright PixController, Inc., All rights reserved.

<http://www.pixcontroller.com>

sales@pixcontroller.com

724-733-0970